

OPEN LOOP CH450 SOLAR HOT WATER



GLOBAL LEADERS



Chromagen solar water heaters use the Sun's unlimited FREE energy to provide up to 80% of your hot water.

When these savings are combined with either State rebates, or the Federal Government initiated Renewable Energy Certificates Scheme, a Chromagen solar hot water system is the obvious economical choice.

Global Leaders

Chromagen is a Global Leader in the solar hot water industry. Founded in 1962, we have designed and manufactured a method of solar energy absorption, transfer and storage so advanced and effective, that we can boast of having over a million satisfied customers in over 40 countries around the world.

Chromagen Pty Ltd is a fully Australian owned company, staffed by a team of solar hot water experts with many years of combined experience. This ensures that you not only receive the highest quality products, Chromagen backs it up with high quality after sales service and support.

Aesthetically pleasing design, no more tank on the roof

Chromagen's 450 litre split solar water heaters are designed for larger families, or households connected to 'Off Peak' electricity. They consist of our high performance roof mounted solar collectors, matched with our range of high quality, technologically advanced ground mounted hot water storage tanks. Available in either Gas or Electric boosted models, a 450 litre Chromagen split solar system will not detract from the appearance of your home.

Steaming Hot water 24/7 – with Solar / Gas or Solar / Electric

When you choose the option of fitting either an Eternity 5 ½ Star rated continuous flow Gas water heater, or an 'off peak' electric element as the 'booster' for your new solar water heater, you'll have hot water 24 hours a day, 7 days a week. Just imagine those long hot showers on those cold winter days.

Super Performance

The key to Chromagen's legendary performance and efficiency lies in our unique solar collector design. For example, independent testing shows that a Chromagen system with only two CR120 Black Chrome solar collectors, outperforms similar competitor products with three solar collectors.

Our larger solar collection area, ultrasonically welded all copper construction, and Black Chrome surface combine to produce a solar collector that is twice as efficient as the aluminium and steel black paint collectors used by a leading competitor.

Highest Quality – Highest Performance

Our range of solar water heaters are so efficient, that they attract the highest government incentives, designed to encourage Australians to utilize our abundant solar energy resource. Plus – the quality of Chromagen systems is second to none – which is why we can offer a very attractive 7 year warranty. Add these two features together – super performance and long life – and the benefits equal higher savings on running costs over a longer life cycle.

Your local Dealer / Distributor is:



Chromagen Pty Ltd

☎ 1300 367 565

www.chromagen.com.au



SYSTEM SPECIFICATIONS



hot water and solar solutions

Tank	Description	450 litre
A (mm)	Tank Width	730
B (mm)	Tank Height	1720
C (mm)	Cold water inlet	80
D (mm)	Hot Water outlet	1480
E (mm)	Collector hot return	580
F (mm)	Collector cold flow	210
G (mm)	Drain Plug	80
H (mm)	PTR Valve	1480
Weight	Kilograms (empty)	150

Collector	Length (mm)	Width (mm)	Weight Empty (Kg)	Weight Full (Kg)
CR90	1820	930	32	35
CR100	1900	1090	39	42
CR110	2190	1090	44	48
CR120	2190	1290	51	56

Models:	Eternity G16	Eternity G20	Eternity G26
Gas Input MJ/h	125	160	200
Water Inlet Pressure kPa	260 min. 1200 max.		
Dimensions mm	H:575 W:350 D:165	H:575 W:350 D:165	H:575 W:350 D:170
Weight Kg	16	16	17
Gas Connection mm	20 BSP		
Water Connections	15 BSP	15 BSP	20 BSP
Ignition	Electronic		
Gas Type	Natural Gas/LPG		
Electrical Supply V	240AC		
Energy Ratings	5.2 Stars	5.2 Stars	5.8 Stars

Specifications are subject to change without notice.

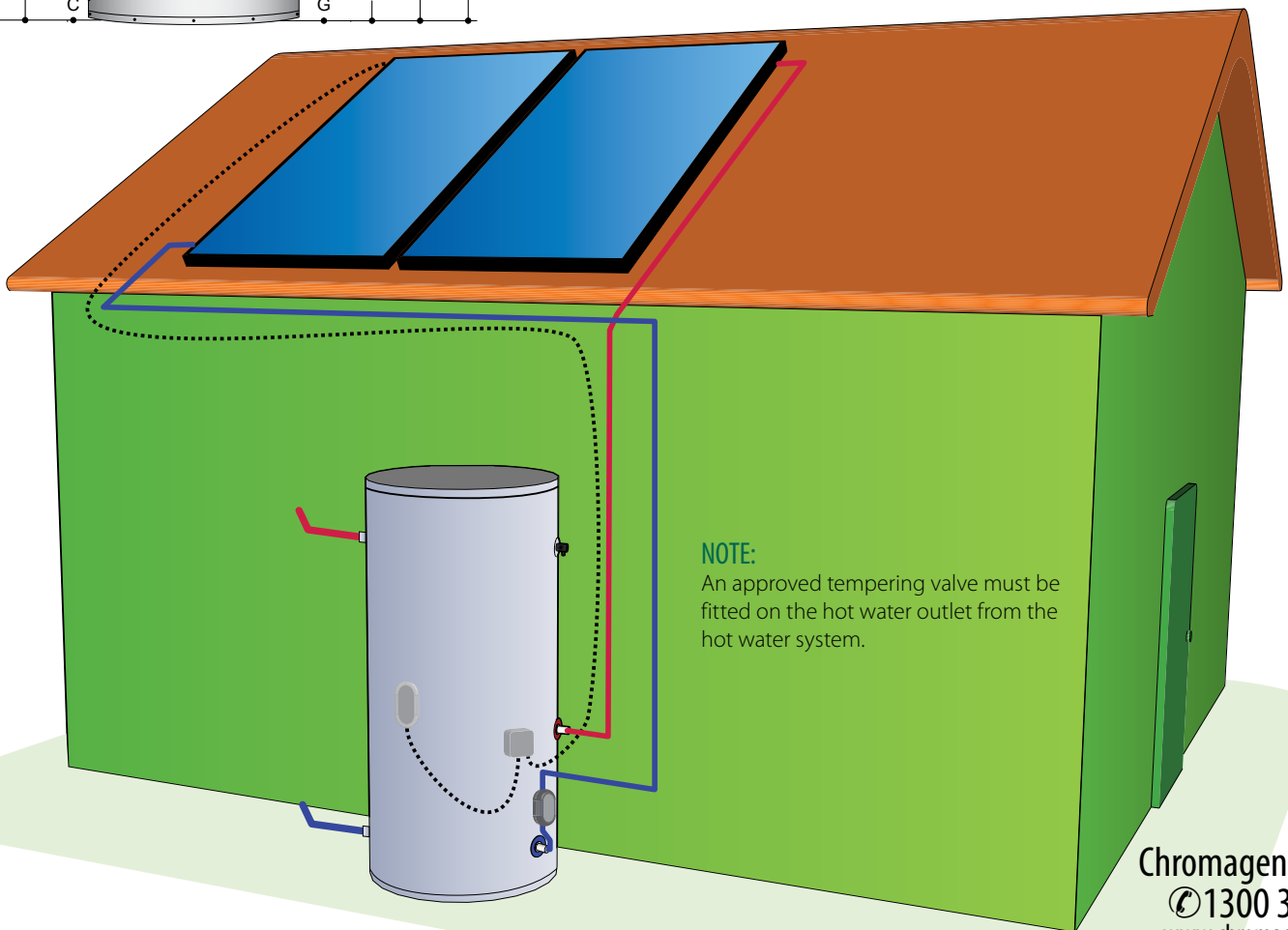
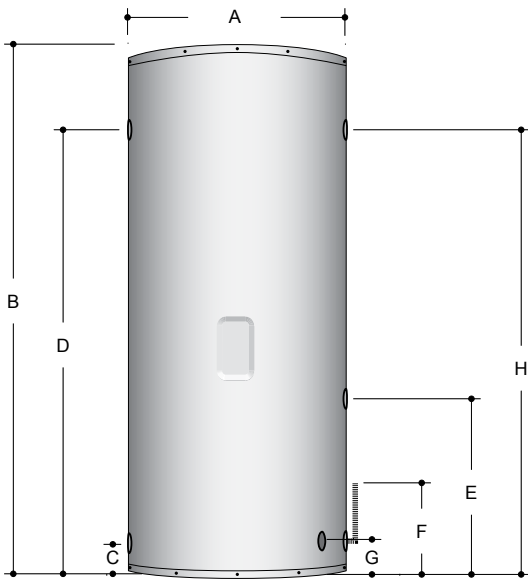

Chromagen Pty Ltd
 1300 367 565
www.chromagen.com.au